

# ! ATTENTION



**SURFACES CAN BECOME VERY HOT!  
ALWAYS USE PROTECTIVE GLOVES!**

*During combustion, thermal energy is released that significantly increases the heat of surfaces, doors, handles, controls, glass, exhaust pipes, and even the front of the appliance. Avoid contact with those elements if not wearing protective clothing (protective gloves included). Make sure children are aware of the danger and keep them away from the stove during operation.*

## ENGLISH - CONTENTS

<b>WARNINGS</b> .....	<b>25</b>
<b>SAFETY</b> .....	<b>25</b>
<b>GENERAL PRECAUTIONS</b> .....	<b>28</b>
<b>DECLARATION OF CONFORMITY OF THE MANUFACTURER</b> .....	<b>28</b>
<b>INSTALLATION REGULATIONS</b> .....	<b>28</b>
<b>FIRE SAFETY</b> .....	<b>29</b>
IN A EMERGENCY .....	29
<b>TECHNICAL DESCRIPTION</b> .....	<b>30</b>
<b>TECHNICAL DATA</b> .....	<b>32</b>
<b>ELECTRICAL CONNECTION</b> .....	<b>32</b>
<b>FLUE</b> .....	<b>33</b>
CHIMNEY POT.....	33
CONNECTION TO THE CHIMNEY.....	34
CONNECTING A FIREPLACE OR OPEN HEARTH TO THE FLUE.....	34
VENTILATION AND AERATION OF THE INSTALLATION PREMISES.....	35
<b>ALLOWED / NOT ALLOWED FUELS</b> .....	<b>36</b>
<b>LIGHTING</b> .....	<b>37</b>
LOW EMISSION FIRE LIGHTING .....	37
<b>NORMAL OPERATION</b> .....	<b>38</b>
USE OF THE OVEN (IF PRESENT).....	38
OPERATION IN TRANSITION PERIODS .....	38
<b>MAINTENANCE AND CARE</b> .....	<b>39</b>
PERIODIC CLEANING UNDER USER'S RESPONSIBILITY .....	39
GLASS CLEANING.....	39
CLEANING OUT THE ASHES .....	39
CLEANING THE FLUE.....	39
MAJOLICAS (IF PRESENT) .....	40
PRODUCTS MADE OF NATURAL STONE (IF PRESENT).....	40
VARNISHED PRODUCTS (IF PRESENT) .....	40
ENAMELLED PRODUCTS (IF PRESENT).....	40
CHROMIUM-COMPONENTS (IF PRESENT) .....	40
LATERAL HANDRAIL (IF PRESENT) .....	40
CLEANING OF THE HEARTH GRATE .....	40
CAST IRON COOKING PLATE AND RINGS.....	40
STAINLESS STEEL FRAME (WHERE EXISTING) .....	40
STAINLESS STEEL COMPONENTS .....	41
MAINTENANCE OF THE OVEN.....	41
CLEANING OF THE COLLECTION CASING COOKING THROUGH THE OVEN.....	41
SUMMER STOP .....	41
<b>ROUTINE MAINTENANCE PERFORMED BY QUALIFIED TECHNICIANS</b> .....	<b>42</b>
GASKETS.....	42
CONNECTION TO THE FLUE .....	42
<b>CALCULATION OF THE THERMAL POWER</b> .....	<b>42</b>
<b>TROUBLESHOOTING</b> .....	<b>43</b>
<b>DISPOSAL</b> .....	<b>43</b>
<b>INSTALLATION</b> .....	<b>111</b>
LEVELLING AND ALIGNMENT OF THE COOKER.....	112
REPLACING OF THE UPPER PART (40 MM TOP – OPTIONAL).....	115
REAR EXHAUST SMOKE OUTLET.....	117
LATERAL EXHAUST SMOKE OUTLET DX-SX .....	118
REVERSING OF THE DOORS .....	121
SLIDING GUIDES FOR OVEN GRILL - POSITIONING. ....	125
<b>DIMENSIONS</b> .....	<b>127</b>

*We thank you for having chosen our company; our product is a great heating solution developed from the most advanced technology with top quality machining and modern design, aimed at making you enjoy the fantastic sensation that the heat of a flame gives, in complete safety.*

## **WARNINGS**

This instructions manual is an integral part of the product: make sure that it always accompanies the appliance, even if transferred to another owner or user, or if transferred to another place. If it is damaged or lost, request another copy from the area technician. This product is intended for the use for which it has been expressly designed. The manufacturer is exempt from any liability, contractual and extracontractual, for injury/damage caused to persons/animals and objects, due to installation, adjustment and maintenance errors and improper use.

**Installation must be performed by qualified staff, which assumes complete responsibility for the definitive installation and consequent good functioning of the product installed. One must also bear in mind all laws and national, regional, provincial and town council Standards present in the country in which the appliance has been installed, as well as the instructions contained in this manual.**

**The use of the appliance must comply with all local, regional, national and European regulations.**

**The Manufacturer cannot be held responsible for the failure to comply with such precautions.**

**After removing the packaging, ensure that the content is intact and complete. Otherwise, contact the dealer where the appliance was purchased. All electric components (where existing) that make up the product must be replaced with original spare parts exclusively by an authorised after-sales centre, thus guaranteeing correct functioning.**

## **SAFETY**

**◆ THE APPLIANCE MAY BE USED BY CHILDREN 8 YEARS OF AGE OR OLDER AND INDIVIDUALS WITH REDUCED PHYSICAL, SENSORY, OR MENTAL CAPACITIES OR WITHOUT EXPERIENCE OR THE NECESSARY KNOWLEDGE, PROVIDED THAT THEY ARE SUPERVISED OR HAVE**

RECEIVED INSTRUCTIONS ON SAFE USE OF THE APPLIANCE AND THAT THEY UNDERSTAND THE INHERENT DANGERS.

- ◆ THE GENERATOR MUST NOT BE USED BY PERSONS (INCLUDING CHILDREN) WITH REDUCED PHYSICAL, SENSORY AND MENTAL CAPACITIES OR WHO ARE UNSKILLED PERSONS, UNLESS THEY ARE SUPERVISED AND TRAINED REGARDING USE OF THE APPLIANCE BY A PERSON RESPONSIBLE FOR THEIR SAFETY.
- ◆ THE CLEANING AND MAINTENANCE REQUIRED BY THE USER MUST NOT BE PERFORMED BY CHILDREN WITHOUT SUPERVISION.
- ◆ CHILDREN MUST BE CHECKED TO ENSURE THAT THEY DO NOT PLAY WITH THE APPLIANCE.
- ◆ DO NOT TOUCH THE GENERATOR WHEN YOU ARE BAREFOOT OR WHEN PARTS OF THE BODY ARE WET OR DAMP.
- ◆ IT IS FORBIDDEN TO MODIFY THE APPLIANCE IN ANY WAY.
- ◆ DO NOT PULL, DISCONNECT, TWIST ELECTRIC CABLES (WHERE EXISTING) LEAVING THE PRODUCT, EVEN IF DISCONNECTED FROM THE ELECTRIC POWER SUPPLY MAINS.
- ◆ IT IS ADVISED TO POSITION THE POWER SUPPLY CABLE (WHERE EXISTING) SO THAT IT DOES NOT COME INTO CONTACT WITH HOT PARTS OF THE APPLIANCE.
- ◆ THE POWER SUPPLY PLUG MUST BE ACCESSIBLE AFTER INSTALLATION.
- ◆ DO NOT CLOSE OR REDUCE THE DIMENSIONS OF THE AIRING VENTS IN THE PLACE OF INSTALLATION. THE AIRING VENTS ARE ESSENTIAL FOR CORRECT COMBUSTION.
- ◆ DO NOT LEAVE THE PACKAGING ELEMENTS WITHIN REACH OF CHILDREN OR UNASSISTED DISABLED PERSONS.
- ◆ THE HEARTH DOOR MUST ALWAYS BE CLOSED DURING NORMAL FUNCTIONING OF THE PRODUCT.
- ◆ WHEN THE APPLIANCE IS FUNCTIONING AND HOT TO THE TOUCH, ESPECIALLY ALL EXTERNAL SURFACES, ATTENTION MUST BE PAID
- ◆ CHECK FOR THE PRESENCE OF ANY OBSTRUCTIONS BEFORE SWITCHING THE APPLIANCE ON FOLLOWING A PROLONGED PERIOD OF INACTIVITY.
- ◆ THIS APPLIANCE MUST NOT BE USED TO BURN WASTE
- ◆ DO NOT USE ANY FLAMMABLE LIQUIDS FOR IGNITION

♦ THE MAJOLICAS (WHERE EXISTING) ARE TOP QUALITY ARTISAN PRODUCTS AND AS SUCH CAN HAVE MICRO-DOTS, CRACKLES AND CHROMATIC IMPERFECTIONS. THESE FEATURES HIGHLIGHT THEIR VALUABLE NATURE. DUE TO THEIR DIFFERENT DILATION COEFFICIENT, THEY PRODUCE CRACKLING, WHICH DEMONSTRATE THEIR EFFECTIVE AUTHENTICITY. TO CLEAN THE MAJOLICAS, IT IS RECOMMENDED TO USE A SOFT, DRY CLOTH. IF A DETERGENT OR LIQUID IS USED, THE LATTER COULD PENETRATE INSIDE THE CRACKLES, HIGHLIGHTING THEM.

## GENERAL PRECAUTIONS

**La NORDICA S.p.A. responsibility is limited to the supply of the appliance.**

THE INSTALLATION MUST BE CARRIED OUT SCRUPULOUSLY ACCORDING TO THE INSTRUCTIONS PROVIDED IN THIS MANUAL AND THE RULES OF THE PROFESSION. INSTALLATION MUST ONLY BE CARRIED OUT BY A QUALIFIED TECHNICIAN WHO WORKS ON BEHALF OF COMPANIES SUITABLE TO ASSUME THE ENTIRE RESPONSIBILITY OF THE SYSTEM AS A WHOLE. **La NORDICA S.p.A. DECLINES ANY RESPONSIBILITY FOR THE PRODUCT THAT HAS BEEN MODIFIED WITHOUT WRITTEN AUTHORISATION AS WELL AS FOR THE USE OF NON-ORIGINAL SPARE PARTS.**

This appliance is not suitable for the use of inexperienced people (included children) or with physical, sensorial and mental reduced capacities. They have to be controlled and educated in the use of the appliance from a responsible person for their security. The children have to be controlled to be sure that they would not play with the appliance. (EN 60335-2-102/7.12).

**IT IS OBLIGATORY TO RESPECT THE NATIONAL AND EUROPEAN RULES, LOCAL REGULATIONS CONCERNING BUILDING MATTER AND ALSO FIREPROOF RULES.**



**NO MODIFICATIONS CAN BE CARRIED OUT TO THE APPLIANCE. La NORDICA S.p.A. cannot be held responsible for lack of respect for such precautions.**

## DECLARATION OF CONFORMITY OF THE MANUFACTURER

OBJECT: **ABSENCE OF ASBESTOS AND CADMIUM**

WE DECLARE THAT THE MATERIALS USED FOR THE ASSEMBLY OF ALL OUR APPLIANCES ARE WITHOUT ASBESTOS PARTS OR ASBESTOS DERIVATES AND THAT IN THE MATERIAL USED FOR WELDING, CADMIUM IS NOT PRESENT, AS PRESCRIBED IN RELEVANT NORM.

OBJECT: **CE N. 1935/2004 REGULATION.**

WE DECLARE THAT IN ALL PRODUCTS WE PRODUCE, THE MATERIALS WHICH WILL GET IN TOUCH WITH FOOD ARE SUITABLE FOR ALIMENTARY USE, ACCORDING TO THE A.M. CE REGULATION.

## INSTALLATION REGULATIONS

INSTALLATION OF THE PRODUCT AND AUXILIARY EQUIPMENT IN RELATION TO THE HEATING SYSTEM MUST COMPLY WITH ALL CURRENT STANDARDS AND REGULATIONS AND TO THOSE ENVISIONED BY THE LAW.

THE INSTALLATION AND THE RELATING TO THE CONNECTIONS OF THE SYSTEM, THE COMMISSIONING AND THE CHECK OF THE CORRECT FUNCTIONING MUST BE CARRIED OUT IN COMPLIANCE WITH THE REGULATIONS IN FORCE BY AUTHORISED PROFESSIONAL PERSONNEL WITH THE REQUISITES REQUIRED BY THE LAW, BEING NATIONAL, REGIONAL, PROVINCIAL OR TOWN COUNCIL PRESENT IN THE COUNTRY WITHIN WHICH THE APPLIANCE IS INSTALLED, BESIDES THESE PRESENT INSTRUCTIONS.

INSTALLATION MUST BE CARRIED OUT BY AUTHORISED PERSONNEL WHO MUST PROVIDE THE BUYER WITH A SYSTEM DECLARATION OF CONFORMITY AND WILL ASSUME FULL RESPONSIBILITY FOR FINAL INSTALLATION AND AS A CONSEQUENCE THE CORRECT FUNCTIONING OF THE INSTALLED PRODUCT.

The Product, assembled and ready for the installation, must be connected with a junction to the existing flue of the house. The junction must be possibly short, straight, horizontal or positioned a little uphill. The connections must be tight.

Before installing the appliance, carry out the following checks:

- UPPER smoke output - REAR - LATERAL
- verify if your structure can support the weight of the appliance. In case of insufficient carrying capacity it is necessary to adopt appropriate measures, **La NORDICA S.p.A.** responsibility is limited to the supply of the appliance (See chapter *TECHNICAL DESCRIPTION*).
- **INSTALLATION** Make sure that the floor can support the weight of the appliance (for ex. distributing weight plate), and if it is made of flammable material, provide suitable insulation (*DIMENSIONS ACCORDING TO REGIONAL REGULATIONS*).
- Make sure that there is adequate ventilation in the room where the appliance is to be installed, with particular attention to windows and doors with tight closing (seal ropes).
- **DO NOT INSTALL THE APPLIANCE IN ROOMS CONTAINING COLLECTIVE VENTILATION DUCTS, HOODS WITH OR WITHOUT EXTRACTOR, TYPE B GAS APPLIANCES, HEAT PUMPS, OR OTHER APPLIANCES THAT, OPERATING AT THE SAME TIME, CAN PUT THE ROOM IN DEPRESSION (ref. UNI 10683 standard).**
- Make sure that the flue and the pipes to which the appliance will be connected are suitable for its operation. **IT IS NOT ALLOWED THE CONNECTION OF VARIOUS APPLIANCES TO THE SAME CHIMNEY.**
- The diameter of the opening for connection to the chimney must at least correspond to the diameter of the flue gas pipe. The opening must be equipped with a wall connection for the insertion of the exhaust pipe and a rosette.
- The unused flue gas exhaust stub pipe must be covered with its respective cap (see chapter *DIMENSIONS*).
- By means of the adjustable feet and using a level make sure that the device is perfectly levelled.
- The installation must be appropriate and has to allow the cleaning and maintenance of the product and the flue.



**LA NORDICA S.P.A. DECLINES ALL RESPONSIBILITY FOR DAMAGE TO THINGS AND/OR PERSONS CAUSED BY THE SYSTEM. IN ADDITION, IT IS NOT RESPONSIBLE FOR ANY PRODUCT MODIFIED WITHOUT AUTHORISATION AND EVEN LESS FOR THE USE OF NON ORIGINAL SPARE PARTS.**

YOUR REGULAR LOCAL CHIMNEY SWEEP MUST BE INFORMED ABOUT THE INSTALLATION OF THE APPLIANCE SO THAT HE CAN CHECK THE CORRECT CONNECTION TO THE CHIMNEY.



## TECHNICAL DESCRIPTION

WOOD BURNING COOKER TO FIT BETWEEN FURNITURE. THE SIDE EXTERNAL COVERINGS ARE EQUIPPED WITH A NATURAL AERATION CERTIFIES SYSTEM AND ACT AS AN EFFICIENT FIREPROOF PROTECTION.

THE FRAME OF THE COOKER IS MADE OF STAINLESS STEEL. THE AIR OPENINGS PLACED ON BOTH SIDES AND REAR SIDE HAVE TO BE KEPT ALWAYS UNOBSTRUCTED TO ENSURE THE NATURAL AIR CIRCULATION INTO THE APPLIANCE. THIS AVOID THE RISKS OF OVERHEATING OF THE APPLIANCE AND FURNITURE IN-BETWEEN IT IS INSTALLED.



**ATTENTION DANGER OF FIRE:** DO NOT OBSTRUCT THE AIR OPENINGS FOR THE NATURAL AIR CIRCULATION NECESSARY TO AVOID OVERHEATING OF THE APPLIANCE AND FURNITURE IN-BETWEEN IT IS INSTALLED. THE SAME APPLIES TO THE AIR OPENINGS ON THE BASE.

The cookers of La NORDICA are suitable to cook on the grill and on the oven and to heat living spaces for some periods or to support an insufficient centralized heating system. They are ideal for holiday apartments and weekend houses or as an auxiliary heating system during the whole year.

AS FUEL, WOOD LOGS IS USED. **THE APPLIANCE WORKS AS AN INTERMITTENT OPERATING APPLIANCE.**

The hearth is totally sheathed with single cast iron and NORDIKER sheets and it is endowed with a pre-adjusted tertiary air for a better combustion. Inside there is a thick flat grate.

The hearth is equipped with a panoramic door with ceramic glass (resistant up to 700 °C) . This allows a wonderful view on the burning flames. Furthermore, it is thus avoided the output of sparks and smoke.

The oven has sliding guides for the chrome-plated steel grill supports. This allows the grill to be pulled out fully from the oven without having to support it making it much more practical to use (**MAXIMUM LOAD 10 kg**).

The position of the sliding guides can be changed in the oven from the lowest (factory setting) to intermediate as indicated in the chapter SLIDING GUIDES FOR OVEN GRILL - POSITIONING.

ACCESSORIES	POKER	GLOVE	RING Ø 100mm air fitting <b>Picture 10</b>
VERONA XXL	SERIES	SERIES	SERIES

**THE HEATING OF THE ENVIRONMENT IS MADE BY IRRADIATION:** through the panoramic glass and the external hot surfaces of the stove, the heat is radiated into the environment.

THE COOKER IS EQUIPPED WITH CONTROLS OF PRIMARY AND SECONDARY AIR BY WHICH IT IS ADJUSTED THE COMBUSTION AIR.

### 1A – PRIMARY AIR CONTROL (**Picture 6**)

On the below part of the door there is the primary air control. This register adjust the passage of air through the ash drawer and the grate in the fuel direction. The primary air is necessary for the combustion process. The ash drawer must be regularly emptied, so that the ash does not obstruct the primary air entry. Through the primary air the fire is also kept alive.

DURING WOOD COMBUSTION, THE REGISTER OF PRIMARY AIR MUST BE OPENED ONLY FOR A WHILE, BECAUSE OTHERWISE THE WOOD BURNS FAST AND THE STOVE MAY OVERHEAT (see chapter NORMAL OPERATION).

### 2A – SECONDARY AIR CONTROL (**Picture 6**)

On the over part of the door there is the secondary air control. Also this register must be opened (then moved to the right), especially for wood combustion (see chapter NORMAL OPERATION).

THE CONTROL REGULATION necessary in order to obtain **NOMINAL CALORIFIC OUTPUT** is the following (see Cap. TECHNICAL DATA):

	PRIMARY air	SECONDARY air	TERTIARY air	B - SMOKES control
VERONA XXL	OPEN <b>Picture 6 - 1A</b>	OPEN	PRE-ADJUSTED	<b>OVEN COOKING USE function</b>



It is possible to get the air PRIMARY, SECONDARY and TERTIARY directly from outside through a flexible tube (**fireproof NOT furnished**, see **Picture 10**).

### B – SMOKES CONTROL (**Picture 6**)

(Conversion of the cooker function **LIGHTING / PLATE** to the **OVEN COOKING**).

The smokes control can be found on the top right corner of the front side of the cooker. This control has two settings: LIGHTING / PLATE when the control bar is pulled out, the combustion gases flow directly into the flue and up to the chimney; OVEN COOKING when the bar is pushed to the back of the cooker, the combustion gases flow around the oven, heating it.



**ATTENTION:** THE LIGHTING VALVE MUST STAY OPENED DURING THE LIGHTING PHASE ONLY. IN CASE IT REMAINS OPENED DURING THE NORMAL FUNCTIONING, IT WILL CAUSE OVERHEATING OF THE APPLIANCE AND ITS COMPONENTS MIGHT GET DAMAGED. MOREOVER THE FUEL CONSUMPTION WILL BE HIGHER.

### C – OVEN LIGHT (**Picture 6**)

The oven is equipped with a light, which turns on by pulling out slightly the lever **C**.





## TECHNICAL DATA

	VERONA XXL
Definition in accordance with	EN 12815
<b>Nominal</b> power in kW	7
Assorbimento elettrico in W	25
<b>Efficiency</b> in %	85,1
<b>Smoke outlet</b> diameter in mm	150
<b>Chimney</b> height $\geq$ (m) - dimension (mm)	(*) 4 - 200 x 200 Ø 200
<b>Chimney draught</b> in Pa (mm H <sub>2</sub> O)	12 ( 1,2 mm H <sub>2</sub> O)
<b>Hourly wood consumption</b> in kg / h (wood with 20% humidity)	1,9
<b>CO</b> measured at 13% oxygen in %	0,084 - 1044 mg/m <sup>3</sup>
<b>Exhaust gas emission</b> in g/s – wood	5,7
<b>Exhaust gas temperature</b> in °C - wood	207
<b>Hearth opening size</b> in mm (W x H)	500 x 160
<b>Hearth size</b> in mm (W x H x D)	568 x 215 x 240
<b>Oven size</b> in mm (W x H x D)	547 x 275 x 450
<b>Type of grill</b>	Movable - flat
<b>Height</b> in mm	850 ÷ 910
<b>Width</b> in mm	800
<b>Depth</b> in mm	600
<b>Weight</b> in kg	200
<b>Fire prevention safety distances</b>	Chapter FIRE SAFETY
<b>Heatable m<sup>3</sup></b> (30 kcal/h x m <sup>3</sup> )	200 (**)
Rated voltage (V)	230
Rated frequency (Hz)	50
Rated input power (W)	25

(\*) The proposed value are indicative. The installation must, in any case, be sized and verified according to the general calculation method in UNI EN13384-1 or by another method of proven efficiency.

(\*\*) For those buildings in which the thermal insulation does not correspond to the instructions on heat protection, the heating volume of the product is: favourable type of building (30 kcal/h x m<sup>3</sup>); less favourable type of building (40 kcal/h x m<sup>3</sup>); unfavourable type of building (50 kcal/h x m<sup>3</sup>).

With thermal insulation in accordance with the regulations regarding energy saving, the heated volume is greater. With temporary heating, in the event of interruptions which last more than 8 hours, the heating capacity is reduced by about 25%.

THE DECLARED TECHNICAL DATA HAVE BEEN ACHIEVED BY BURNING BEECH WOOD CLASS "A1" ACCORDING TO THE REQUIREMENT UNI EN ISO 17225-5 AND WOOD MOISTURE CONTENT LESS THAN 20%. BY BURNING A DIFFERENT KIND OF WOOD THE EFFICIENCY OF THE PRODUCT ITSELF COULD CHANGE AND SOME SPECIFIC ADJUSTMENTS ON THE APPLIANCE COULD BE NEEDED.

## ELECTRICAL CONNECTION

THE INSTALLATION AND THE CONNECTION OF THE PRODUCT HAS TO BE CARRIED OUT BY AUTHORIZED PERSONNEL ACCORDING TO THE CURRENT REGULATIONS (SEE CHAPTER GENERAL PRECAUTIONS). LA NORDICA S.P.A. DECLINES ANY RESPONSIBILITY FOR THE PRODUCT THAT HAS BEEN MODIFIED WITHOUT WRITTEN AUTHORISATION AS WELL AS FOR THE USE OF NON-ORIGINAL SPARE PARTS.



**ATTENTION - DO NOT PLACE THE ELECTRIC CABLE NEARBY HOT PARTS. THE CONTROL UNIT AND THE FEEDING CABLE MUST NOT BE IN CONTACT WITH HOT PARTS. IN ANY CASE, THE POWER CABLE HAS TO BE REPLACED BY AUTHORISED PERSONNEL ONLY (ENTITLED BY LA NORDICA): AUTHORISED DEALERS AND/OR FITTER.**

**CONNECTION:** Connect the electric cable to a bipolar switch with a distance of at least 3 mm between the contacts (Power source 230 V~ 50 Hz, the correct connection to the grounding system is necessary).



**WARNING: THIS OPERATION MUST BE CARRIED OUT WITHOUT POWER SUPPLY !!**  
**WARNING:** THE PRODUCT MUST BE CONNECTED TO THE MAINS WITH A DIFFERENTIAL LINE CUT-OFF SWITCH ACCORDING TO THE REGULATIONS IN FORCE. IMPROPER USE RELIEVES THE MANUFACTURER FROM EACH RESPONSIBILITY.



## CONNECTION TO THE CHIMNEY

Products with automatic door closing (type 1) must operate, for safety reasons, with the furnace door closed (except during the fuel loading or ash removal phases).

Products with non-automatic door closing (type 2) must be connected to their own flue.

Operation with doors open is only allowed when supervised.

THE CONNECTION PIPE TO THE FLUE MUST BE AS SHORT AS POSSIBLE, STRAIGHT HORIZONTAL AND POSITIONED SLIGHTLY IN ASCENT, AND WATERTIGHT.

CONNECTION MUST BE CARRIED OUT WITH STABLE AND ROBUST PIPES, COMPLY WITH ALL CURRENT STANDARDS AND REGULATIONS AND TO THOSE ENVISIONED BY THE LAW, AND BE HERMETICALLY SECURED TO THE FLUE.

The internal diameter of the connection pipe must correspond to the external diameter of the appliance flue gas exhaust stub pipe (DIN 1298).



**ATTENTION:** AS FAR AS CONCERN THE REALISATION OF THE FLUE CONNECTION AND FLAMMABLE MATERIALS PLEASE FOLLOW THE REQUIREMENTS PROVIDED BY UNI 10683 STANDARD. THE FLUE MUST BE PROPERLY SPACED FROM ANY FLAMMABLE MATERIALS OR FUELS THROUGH A PROPER INSULATION OR AN AIR CAVITY. **MINIMUM DISTANCE SAFETY 25 CM.**

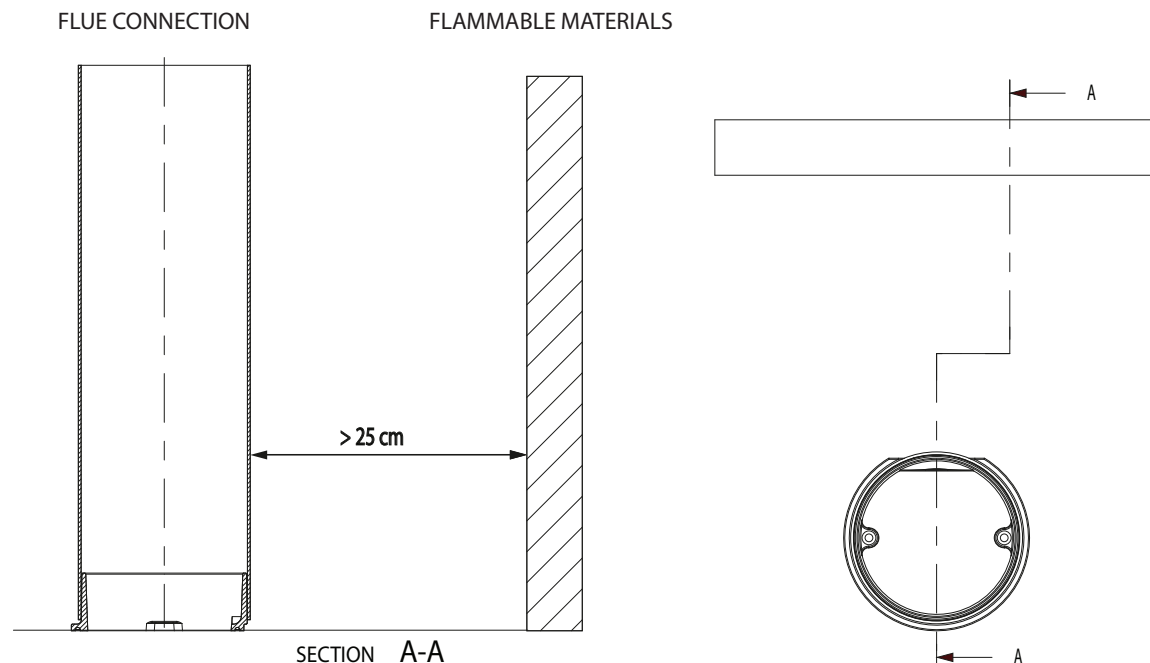

**IMPORTANT: THE UNUSED FLUE GAS EXHAUST HOLE MUST BE COVERED WITH ITS RESPECTIVE CAP** (See chapter: DIMENSIONS).

**The chimney pressure (DRAUGHT) must be at least** - Pascal (see chap. TECHNICAL DATA SHEET). The measurement has always to be carried out with hot device (rated thermal performance).

When the depression exceeds 17 Pa ( $\approx 1.7$  mm of column of water), it is necessary to reduce the same by installing an additional draught regulator (butterfly valve) on the exhaust pipe or in the chimney, according to the regulations in force.



FOR CORRECT APPLIANCE OPERATION, IT IS ESSENTIAL THAT SUFFICIENT AIR FOR COMBUSTION IS INTRODUCED INTO THE PLACE OF INSTALLATION (see paragraph VENTILATION AND AERATION OF THE INSTALLATION PREMISES).

## CONNECTING A FIREPLACE OR OPEN HEARTH TO THE FLUE

The flue gas channel is the stretch of piping which connects the product to the flue. In the connection, these simple but extremely important principles must be respected:

- UNDER NO CIRCUMSTANCES USE A FLUE GAS CHANNEL WITH A DIAMETER LESS THAN THAT OF THE EXHAUST CLAMP WITH WHICH THE PRODUCT IS EQUIPPED;
- EACH METRE OF THE HORIZONTAL STRETCH OF THE FLUE GAS CHANNEL CAUSES A SLIGHT LOSS OF HEAD WHICH MUST BE COMPENSATED IF NECESSARY BY ELEVATING THE FLUE;
- THE HORIZONTAL STRETCH MUST NEVER EXCEED 2 METRES (UNI 10683);

- EACH BEND OF THE FLUE GAS CHANNEL SLIGHTLY REDUCES THE FLUE DRAUGHT WHICH MUST BE COMPENSATED IF NECESSARY BY ELEVATING IT SUITABLY;
- THE UNI 10683 – ITALY REGULATION REQUIRES THAT UNDER NO CIRCUMSTANCES MUST THERE BE MORE THAN 2 BENDS OR VARIATIONS IN DIRECTION INCLUDING THE INTAKE INTO THE FLUE.

If the user wishes to use the flue as a fireplace or open hearth, it is necessary to seal the hood below the entrance point of the flue gas channel pos. **A** **Picture 5**.

If the flue is then too big (e.g. 30x40cm or 40x50cm), it is necessary to intubate it with a stainless steel tube with a diameter of at least 200mm, pos. **B**, taking care to close the remaining spaces between the pipe and the flue immediately under the chimney pot pos. **C**.

## VENTILATION AND AERATION OF THE INSTALLATION PREMISES

AS THE PRODUCT DRAW THEIR COMBUSTION AIR FROM THE PLACE OF INSTALLATION, IT IS **MANDATORY** THAT IN THE PLACE ITSELF, A SUFFICIENT QUANTITY OF AIR IS INTRODUCED. IF WINDOWS AND DOORS ARE AIRTIGHT (E.G. BUILT ACCORDING TO ENERGY SAVING CRITERIA), IT IS POSSIBLE THAT THE FRESH AIR INTAKE IS NO LONGER GUARANTEED AND THIS JEOPARDISES THE DRAUGHT OF THE APPLIANCE AND YOUR HEALTH AND SAFETY.

**IMPORTANT:** For a better comfort and corresponding oxygenation of environment, the combustion air can be directly withdrawn at the outside through a junction which is to be connected with a flexible pipe. The connection pipe (not furnished) must be flat with a minimum diameter of **Picture 10**, a maximum length of 3 m and with no more than 3 bends. If there is a direct connection with the outside it must be endowed with a special windbreak.

THERE **MANDATORY** BE SUFFICIENT QUANTITY OF AIR FOR COMBUSTION AND RE-OXYGENATION OF THE ROOM TO ENSURE THE DEVICE WILL WORK PROPERLY. There should therefore be vents letting air in from outside the building and enabling circulation of air for combustion even when the doors and windows are closed.

The air inlets must meet the following requirements:

- THEY MUST BE PROTECTED WITH GRIDS, METAL MESH, ETC., BUT WITHOUT REDUCING THE NET USEFUL SECTION;
- THEY MUST BE MADE SO AS TO MAKE THE MAINTENANCE OPERATIONS POSSIBLE;
- POSITIONED SO THAT THEY CANNOT BE OBSTRUCTED;
- ANY EXTRACTOR HOODS IN THE ROOM WHERE THE DEVICE IS INSTALLED MUST NOT OPERATE AT THE SAME TIME as this could cause smoke to enter the room, even with the fireplace's door closed.

The clean and non-contaminated air flow can also be obtained from a room adjacent to that of installation (indirect aeration and ventilation), as long as the flow takes place freely through permanent openings communicating with the outside.

THE ADJACENT ROOM CANNOT BE USED AS A GARAGE, OR TO STORE COMBUSTIBLE MATERIAL OR FOR ANY OTHER ACTIVITY WITH A FIRE HAZARD, BATHROOM, BEDROOM OR COMMON ROOM OF THE BUILDING.

Ventilation is deemed sufficient when the room is equipped with air inlets according to the table:

Appliance categories	Reference standard	Percentage of the net opening section with respect to the appliance fumes outlet section	Minimum net opening value of the ventilation duct
Fireplaces	UNI EN 13229	50%	200 cm <sup>2</sup>
Stoves	UNI EN 13240	50%	100 cm <sup>2</sup>
Cookers	UNI EN 12815	50%	100 cm <sup>2</sup>



INSTALLATION IN PREMISES WITH FIRE HAZARDS IS FORBIDDEN. INSTALLATION IN RESIDENTIAL PREMISES IN WHICH, IN ANY CASE, THE DEPRESSION MEASURED DURING INSTALLATION BETWEEN THE INTERNAL AND EXTERNAL ENVIRONMENT IS GREATER THAN 4 PA - REFERENCE FOR ITALY ACCORDING TO STANDARD UNI10683.

ALL NATIONAL, REGIONAL, PROVINCIAL AND MUNICIPAL LAWS AND STANDARDS IN FORCE IN THE COUNTRY WHERE THE APPLIANCE IS INSTALLED MUST BE COMPLIED WITH.



## LIGHTING



**WARNING:** After the first ignition you can smell bad odours (owing to the drying of the glue used in the garnitures or of the paint) which disappear after a brief using of the appliance.

**IT MUST BE ENSURED, IN ANY CASE, A GOOD VENTILATION OF THE ENVIRONMENT.** UPON THE FIRST IGNITION WE SUGGEST LOADING A REDUCED QUANTITY OF FUEL AND SLIGHTLY INCREASING THE CALORIFIC VALUE OF THE EQUIPMENT.

**IT IS FORBIDDEN TO USE ANY LIQUID SUBSTANCE AS FOR EX. ALCOHOL, GASOLINE, OIL AND SIMILAR.**

**NEVER SWITCH ON THE DEVICE WHEN THERE ARE COMBUSTIBLE GASES IN THE ROOM.**

To perform a correct first lighting of the products treated with paints for high temperature, it is necessary to know the following information:

- The construction materials of the involved products are not homogeneous, in fact there are simultaneously parts in cast iron, steel, refractory material and majolica;
- The temperature to which the body of the product is subject is not homogeneous: from area to area, variable temperatures within the range of 300°C - 500°C are detected;
- During its life, the product is subject to alternated lighting and extinguishing cycles in the same day, as well as to cycles of intense use or of absolute standstill when season changes;
- The new appliance, before being considered seasoned has to be subject to many start cycles to allow all materials and paints to complete the various elastic stresses;
- In detail, initially it is possible to remark the emission of smells typical of metals subject to great thermal stress, as well as of wet paint.

Therefore, it is extremely relevant to take these easy steps during the lighting:

1. Make sure that a strong air change is assured in the room where the appliance is installed.
2. During the first starts, do not load excessively the combustion chamber (about half the quantity indicated in the instructions manual) and keep the product continuously ON for at least 6-10 hours with the registers less open than the value indicated in the instructions manual.
3. Repeat this operation for at least 4-5 or more times, according to your possibilities.
4. Then load more and more fuel (following in any case the provisions contained in the installation booklet concerning maximum load) and, if possible, keep the lighting periods long avoiding, at least in this initial phase, short ON/OFF cycles.
5. **DURING THE FIRST STARTS, NO OBJECT SHOULD BE LEANED ON THE APPLIANCE AND IN DETAIL ON ENAMELLED SURFACES. ENAMELLED SURFACES MUST NOT BE TOUCHED DURING HEATING.**
6. Once the «break-in» has been completed, it is possible to use the product as the motor of a car, avoiding abrupt heating with excessive loads.

To light the fire, it is suggested to use small wood pieces together with paper or other traded lighting means.

The openings for air (primary and secondary) must be opened together (you must open the eventual Ignition control, and butterfly valve placed on the pipe of smokes exhaust). When the wood starts burning, you may load other fuels and adjust the air for combustion according to the instructions on paragraph TECHNICAL DESCRIPTION.

**PLEASE ALWAYS BE PRESENT DURING THIS PHASE.**



**MAXIMUM LOAD OF WOOD TO AVOID DANGEROUS OVERHEATING:**

**CAUTION: NEVER LOAD MORE WOOD THAT THE HOURLY CONSUMPTION INDICATED.** IF THESE INDICATIONS ARE NOT OBSERVED, THE STOVE WILL BE IRREPARABLY DAMAGED, THE OUTER PARTS WILL BECOME VERY HOT AND IF, IN CONTACT WITH OTHER COMBUSTIBLE PARTS, COMPLIANCE WITH THE SAFETY TEMPERATURES CANNOT BE GUARANTEED **Figure 4 -A2.**

**THE WARRANTY DOES NOT COVER THE DAMAGES DUE TO OVERHEATING OF THE EQUIPMENT.**

## LOW EMISSION FIRE LIGHTING

Smokeless combustion is a way of lighting a fire able to significantly reduce the emission of harmful substances. The wood burns gradually from the top downwards, so combustion is slower and more controlled. Burnt gases pass through the high temperatures of the flame and therefore burn almost completely.

Place the logs in the hearth a certain distance apart as shown in the **Picture 7**. Arrange the largest at the bottom and the smallest at the top, or vertically in the case of tall narrow combustion chambers. Place the fire starter module on top of the pile, arranging the first logs in the module at right angles to the pile of wood.

**FIRE STARTER MODULE.** THIS FIRE STARTER MODULE REPLACES A PAPER OR CARDBOARD STARTER.

Prepare four logs, 20 cm long with a cross section of 3 cm by 3 cm **Picture 7**. Cross the four logs and place them on top of the pile of wood at right angles, with the fire lighter (wax impregnated wood fibre for example) in the middle. The fire can be lit with a match. If you want, you can use thinner pieces of wood. In this case, you will need a larger quantity.

Keep the flue gas exhaust valve and combustion air regulator open.

After lighting the fire, leave the combustion air regulator open in the position shown below .

FUEL	PRIMARY Air	SECONDARY Air	TERTIARY air
Wood	CLOSED	1/2 OPEN	PRE-ADJUSTED

**IMPORTANT:**

- do not add further wood between one complete load and the next;
- do not suffocate the fire by closing the air intakes;
- regular cleaning by a chimney sweep reduces fine particle emissions.
- These instructions are backed by ENERGIA Legno SVIZZERA [www.energia-legno.ch](http://www.energia-legno.ch)

## NORMAL OPERATION

After having positioned the registers correctly, insert the indicated hourly wood load avoiding overloads that cause anomalous stresses and deformations (according to the instructions on paragraph TECHNICAL DESCRIPTION). **YOU SHOULD ALWAYS USE THE PRODUCT WITH THE DOOR CLOSED IN ORDER TO AVOID DAMAGES DUE TO OVERHEATING (FORGE EFFECT). THE INOBSERVANCE OF THIS RULE MAKES THE WARRANTY EXPIRE.**

For safety reasons the door of the appliances with constructive system 1, must be opened only for the loading of the fuel or for removing the ashes, while during the operation and the rest, the door of the hearth must remain closed.

The appliances with constructive system 2 must be connected to their own flue. The operating with open door is allowed under supervision.



**IMPORTANT: FOR SAFETY REASONS THE DOOR OF THE HEARTH CAN BE OPENED ONLY FOR THE LOADING OF THE FUEL. THE HEARTH DOOR MUST ALWAYS REMAIN CLOSED DURING OPERATION OR REST.**

With the controls positioned on the front of the appliance it is possible to adjust the heat emission of the hearth. They have to be opened according to the calorific need. The best combustion (with minimum emissions) is reached when, by loading the wood, most part of the air for combustion flows through the secondary air register.

**NEVER OVERLOAD THE APPLIANCE.** TOO MUCH FUEL AND TOO MUCH AIR FOR THE COMBUSTION MAY CAUSE OVERHEATING AND THEN DAMAGE THE APPLIANCE. YOU SHOULD ALWAYS USE THE APPLIANCE WITH THE DOOR CLOSED IN ORDER TO AVOID DAMAGES DUE TO OVERHEATING (FORGE EFFECT). **THE INOBSERVANCE OF THIS RULE MAKES THE WARRANTY EXPIRE.**



**MAXIMUM LOAD OF WOOD TO AVOID DANGEROUS OVERHEATING:**

**CAUTION: NEVER LOAD MORE WOOD THAT THE HOURLY CONSUMPTION INDICATED.** IF THESE INDICATIONS ARE NOT OBSERVED, THE STOVE WILL BE IRREPARABLY DAMAGED, THE OUTER PARTS WILL BECOME VERY HOT AND IF, IN CONTACT WITH OTHER COMBUSTIBLE PARTS, COMPLIANCE WITH THE SAFETY TEMPERATURES CANNOT BE GUARANTEED **Figure 4 -A2**

The adjustment of the registers necessary to reach the rated calorific yield with a depression at the stack of 12 Pa 1,2mm of column of water) is the following one: see chapter TECHNICAL DESCRIPTION. **THE APPLIANCE WORKS AS AN INTERMITTENT OPERATING APPLIANCE.**

BESIDES THE ADJUSTMENT OF THE AIR FOR THE COMBUSTION, THE INTENSITY OF THE COMBUSTION AND CONSEQUENTLY THE THERMAL PERFORMANCE OF THE DEVICE IS INFLUENCED BY THE STACK. A GOOD DRAUGHT OF THE STACK REQUIRES A STRICTER ADJUSTMENT OF AIR FOR COMBUSTION, WHILE A POOR DRAUGHT REQUIRES A MORE PRECISE ADJUSTMENT OF AIR FOR COMBUSTION.

To verify the good combustion, check whether the smoke coming out from the stack is transparent.

If it is white, it means that the device is not properly adjusted or the wood is too wet; if instead the smoke is gray or black, it signals that the combustion is not complete (it is necessary a greater quantity of secondary air).



**WARNING: WHEN FUEL IS ADDED ONTO THE EMBERS IN THE ABSENCE OF A FLAME, A CONSIDERABLE AMOUNT OF FUMES MAY DEVELOP. SHOULD THIS HAPPEN, AN EXPLOSIVE MIXTURE OF GAS AND AIR MAY FORM, AND IN EXTREME CASES AN EXPLOSION MAY OCCUR. FOR SAFETY REASONS IT IS ADVISABLE TO PERFORM A NEW LIGHTING PROCEDURE WITH THE USE OF SMALL STRIPS.**

## USE OF THE OVEN (IF PRESENT)

The oven is equipped with a light, which turns on by pulling out slightly the lever **C**. For replacement see chap. MANTEINANCE OF THE OVEN. Place the smoke controller in the position USE OF THE OVEN (see chap. TECHNICAL DESCRIPTION)

Thanks to the air flow for the combustion, the temperature of the oven may become remarkably affected. A sufficient flue of the chimney and of the channels, well cleaned for the flow of burning smokes around the oven are fundamental for a good cooking result. Thick cakes and big roasts must be introduced in the lowest level. Flat cakes and biscuits must reach the medium level. The upper level may be used to heat or grill. The oven pan and the chrome plated oven grille may be located on different plans (see chapter Technical Description - ACCESSORIES).

**WHEN COOKING FOOD WITH HIGH HUMIDITY, CAKES WITH FRUIT OR FRUIT ITSELF, WATER OF CONDENSATION WILL BE PRODUCED. DURING THE COOKING PROCESS SOME WATER VAPOUR IN THE FORM OF DROPS OF CONDENSED WATER CAN DEPOSIT ONTO THE TOP AND THE SIDE OF THE DOOR. IT IS A PHYSICAL PHENOMENON.**



OPEN THE EXCESS STEAM VALVE **BEFORE LIGHTING THE COOKER** TO AVOID THE RISK OF BURNS.

By opening the door briefly and carefully (1 or 2 times, or even often in case of longer cooking times) you can let out the steam from the cooking compartment and reduce condensation significantly.

## OPERATION IN TRANSITION PERIODS

DURING TRANSITION PERIODS WHEN THE EXTERNAL TEMPERATURES ARE HIGHER, IF THERE IS A SUDDEN INCREASE OF TEMPERATURE IT CAN HAPPEN THAT THE COMBUSTION GASES INSIDE THE FLUE CANNOT BE COMPLETELY SUCKED UP. THE EXHAUST GASES DO NOT COME OUT COMPLETELY (INTENSE SMELL OF GAS).

In this case, shake the grating more frequently and increase the air for the combustion. Then, load a reduced quantity of fuel in order to permit a rapid burning (growing up of the flames) and the stabilization of the draught.



THEN, CHECK THAT ALL OPENINGS FOR THE CLEANING AND THE CONNECTIONS TO THE STACK ARE AIR-TIGH. **IN CASE OF DOUBT, DO NOT OPERATE THE PRODUCT.**

## MAINTENANCE AND CARE

### ALWAYS FOLLOW THE INSTRUCTIONS IN COMPLETE SAFETY!

- MAKE SURE THAT THE POWER CORD IS UNPLUGGED (IF PRESENT).
- THAT THE GENERATOR IS COLD ALL OVER.
- THE ASHES ARE COMPLETELY COLD.
- ENSURE EFFICIENT AIR EXCHANGE IN THE ROOM DURING THE PRODUCT CLEANING OPERATIONS.
- POOR CLEANING WILL COMPROMISE CORRECT OPERATION AND SAFETY!

### PERIODIC CLEANING UNDER USER'S RESPONSIBILITY

The periodic cleaning operations, as indicated in this use and maintenance manual, must be performed with the utmost care after reading the instructions, procedures and frequency described in this use and maintenance manual.

CHECK THE EXTERNAL AIR INTAKE, BY CLEANING IT, AT LEAST ONCE A YEAR. THE STACK MUST BE REGULARLY SWEEPED BY THE CHIMNEY SWEEPER. LET YOUR CHIMNEY SWEEPER IN CHARGE OF YOUR AREA CHECK THE REGULAR INSTALLATION OF THE DEVICE, THE CONNECTION TO THE STACK AND THE AERATION.



**IMPORTANT: THE MAINTENANCE AND CARE MUST BE CARRIED OUT ONLY AND EXCLUSIVELY WITH COLD DEVICE.** You should only use spare parts approved and supplied by **La NORDICA S.p.A.** Please contact your specialized retailer if you require spare parts. **YOU MUST NOT MAKE ANY CHANGES TO THE DEVICE!!!**

### GLASS CLEANING

Thanks to a specific inlet of secondary air, the accumulation of dirty sediments on the glass-door is reduced with efficacy. Nevertheless this can never be avoided by using solid fuels ( particularly wet wood ) and it has not to be understood as a defect of the appliance.



**IMPORTANT: THE CLEANING OF THE SIGHT GLASS MUST BE CARRIED OUT ONLY AND EXCLUSIVELY WITH COLD DEVICE TO AVOID THE EXPLOSION OF THE SAME.**

For the cleaning, it is possible to use specific products or a wet newspaper paper ball passed in the ash to rub it. **DO NOT USE CLOTHS, ABRASIVE OR CHEMICALLY AGGRESSIVE PRODUCTS BY CLEANING THE HEARTH GLASS.**

The correct lighting phase, the use of proper quantities and types of fuels, the correct position of the secondary air regulator, enough draught of the chimney-flue and the presence of combustion air are the essential elements for the optimal functioning of the appliance and for the cleaning of the glass.



**BREAK OF GLASSES:** Given that the glass-ceramic glasses resist up to a heat shock of 750°C, they are not subject to thermal shocks. Their break can be caused only by mechanic shocks (bumps or violent closure of the door, etc.). **THEREFORE, THEIR REPLACEMENT IS NOT INCLUDED IN THE WARRANTY.**

### CLEANING OUT THE ASHES

All the devices are equipped with a hearth grating and an ash drawer for the collection of the ashes **Picture 8**.

It is suggested to empty periodically the ash drawer and to avoid it fills completely in order not to overheat the grating. Moreover, it is suggested to leave always 3-4 cm of ash in the hearth.



**CAUTION: THE ASHES REMOVED FROM THE HEARTH HAVE TO BE STORED IN A CONTAINER MADE OF FIRE-RESISTANT MATERIAL EQUIPPED WITH AN AIR-TIGHT COVER. THE CONTAINER HAS TO BE PLACED ON A FIRE-RESISTANT FLOOR, FAR FROM FLAMMABLE MATERIALS UP TO THE SWITCHING OFF AND COMPLETE COOLING.**

### CLEANING THE FLUE

The correct lighting phase, the use of proper quantities and types of fuels, the correct position of the secondary air regulator, enough draught of the chimney-flue and the presence of combustion air are the essential elements for the optimal functioning of the appliance.

THE DEVICE SHOULD BE COMPLETELY CLEANED AT LEAST ONCE A YEAR OR EVERY TIME IT IS NEEDED (in case of bad working and low yield). AN EXCESSIVE DEPOSIT OF SOOT CAN CAUSE PROBLEMS IN THE DISCHARGE OF SMOKES AND FIRE IN THE FLUE.



**THE CLEANING MUST BE CARRIED OUT EXCLUSIVELY WITH COLD EQUIPMENT.** THIS OPERATION SHOULD BE CARRIED OUT BY A CHIMNEY SWEEPER WHO CAN SIMULTANEOUSLY PERFORM AN AUDIT OF THE FLUE (checking of possible deposits).

During the cleaning, it is necessary to remove the ash drawer and the smoke deflectors from the device in order to ease the cleaning of the soot. The deflectors can be easily extracted from their seats since they are not fastened using screws. Once the clearing has been carried out, place them back in their seats (**Picture 9**).



**CAUTION: THE LACK OF THE DEFLECTORS CAUSES A STRONG DEPRESSION, WITH A TOO FAST COMBUSTION, AN EXCESSIVE CONSUMPTION OF WOOD WITH RELATED OVERHEATING OF THE DEVICE.**



## MAJOLICAS (IF PRESENT)

La NORDICA S.p.A. has chosen majolica tiles, which are the result of high-quality artisan work. As they are completely carried out by hand, the majolica may present crackles, speckles, and shadings. These characteristics certify their precious origin. Enamel and majolica, due to their different coefficient of dilatation, produce microcrackles, which show their authentic feature.



FOR THE CLEANING OF THE MAJOLICA WE SUGGEST YOU TO USE A SOFT AND DRY CLOTH;  
**IF YOU USE A DETERGENT OR LIQUID, THE LATTER MIGHT SOAK IN AND HIGHLIGHT THE CRACKLES PERMANENTLY.**

## PRODUCTS MADE OF NATURAL STONE (IF PRESENT)

NATURAL STONE HAS TO BE CLEANED WITH VERY THIN ABRASIVE PAPER OR WITH AN ABRASIVE SPONGE. **DO NOT USE ANY CLEANSER OR FLUID.**

## VARNISHED PRODUCTS (IF PRESENT)

After some years of product use a change in the varnished details colour is totally normal. This is due to the considerable temperature range the product is subject to whenever in use and to the varnish ageing of time passing by.



**ATTENTION:** BEFORE ANY POSSIBLE APPLICATION OF THE NEW VARNISH, DO CLEAN AND REMOVE ALL THE TRACES FROM THE SURFACE WHICH HAS TO BE VARNISHED.

## ENAMELLED PRODUCTS (IF PRESENT)

For the cleaning of enamelled surfaces use soap water or **NOT AGGRESSIVE** and **NOT CHEMICALLY** abrasive detergents.



AFTER THE CLEANING **DO NOT** LET SOAPY WATER OR ANY CLEANSER DRY BUT REMOVE THEM IMMEDIATELY.  
**DO NOT USE SANDPAPER OR STEEL WOOL.**

## CHROMIUM-COMPONENTS (IF PRESENT)

If the components become bluish due to overheating, this can be solved with a suitable product for cleaning. **DO NOT use** abrasives or solvents.

## LATERAL HANDRAIL (IF PRESENT)

The handles, the handrail and the tank water (cookers) should be cleaned to cold with a soft cloth and alcohol .  
**DO NOT USE ABRASIVES OR SOLVENTS.**

## CLEANING OF THE HEARTH GRATE

**IMPORTANT:** if for whatever reason the grill is removed from the furnace, take care to reassemble it with the wider part of the slit facing downwards (See **Picture 8**). This is to aid furnace cleaning.

## CAST IRON COOKING PLATE AND RINGS



**IMPORTANT: TO AVOID RUST DO NOT FORGET** POTS OR PANS ON THE COLD COOKING PLATE. This would create rust rings, unpleasant to see and difficult to remove.  
The cast iron cooking plate and the cast iron rings needs to be periodically cleaned by using sandpaper (grain 150) **WITHOUT TOUCHING THE ENAMELLED PARTS.**

To carry out the cleaning operation remove the smoke outlet spigot and the smoke pipe. The smoke compartment can be cleaned from the front side of the oven (see chap. CLEANING SMOKE COMPARTMENT COOKERS) or from the top. In this case remove the cast iron rings and the cooking plate, as well the smoke outlet spigot and the smoke pipe. The cleaning can be carried out by using a brush and a Hoover.



**ATTENTION: ONCE THE CLEANING OPERATIONS ARE TERMINATED ALL THE PARTS HAVE TO BE RE-ASSEMBLED HERMETICALLY.**

## STAINLESS STEEL FRAME (WHERE EXISTING)

Once you have placed the cast iron cooking plate, make sure to have always 3 mm in-between the cooking plate and the STAINLESS STEEL frame. This gap is important because of the thermal expansions and to avoid chromatic changes of the STAINLESS STEEL frame when hot.

## STAINLESS STEEL COMPONENTS

CLEAN THE STAINLESS STEEL PARTS WITH A NEUTRAL AND NON ABRASIVE DETERGENT ONLY WHEN THE PRODUCT IS COLD.

Use vinegar to clean persistent spots. Then use a soft cloth to dry.

**DO NOT USE SANDPAPER OR STEEL WOOL.**



**IMPORTANT:** to avoid rust in case the product has not been working for a long period, we recommend to grease the cleaned cast iron frame a bit when it is lukewarm (use vaseline or paraffin oil, or oil for sewing machines, or gun oil). Of course the cast iron frame has to be cleaned before next use.

**DO NOT FORGET** POTS OR PANS ON THE COLD COOKING PLATE. THIS WOULD CREATE RUST RINGS, UNPLEASANT TO SEE AND DIFFICULT TO REMOVE!

## MAINTENANCE OF THE OVEN

**TO AVOID THE POSSIBLE FORMING OF RUST IT IS RECOMMENDED:**

- Using the VALVE FOR EXCESS STEAM in the oven (see chapter: TECHNICAL DESCRIPTION);
- To let the steam getting out of the oven to reduce the formation of any condensation by opening the door briefly and carefully (1 or 2 times, or more often in case of cooking food very humid and with longer cooking times);
- Remove the food from the oven once cooked. Letting the food to chill in the oven at a temperature below 150 °C results in the forming of condensation;
- After cooking, leave the oven door partially open to dry out any condensation;

**REPLACING OF THE OVEN LIGHT BULB.**



**WARNING: THIS OPERATION MUST BE CARRIED OUT WITHOUT POWER SUPPLY !!** AFTER HAVING DISCONNECTED THE ELECTRICAL CONNECTION REPLACE THE LIGHT BULB INSIDE THE OVEN AS INDICATED IN THE PICTURE

**ALWAYS FOLLOW THE INSTRUCTIONS IN COMPLETE SAFETY!**

- MAKE SURE THAT THE POWER CORD IS UNPLUGGED.
- That the generator is cold all over.

Should you need to replace the oven light bulb, use a new one with the same technical specs indicated in the **Picture 9**.

## CLEANING OF THE COLLECTION CASING COOKING THROUGH THE OVEN

The smokes collection casing can be cleaned either through the oven (remove the horizontal sheet metal which is the base of the oven See **Picture 9**) the cooker or from the top.

To this purpose remove the circles of the cooking plate and disassemble the smokes pipe from the exhaust small trunk.

Cleaning can be made with a brush and a vacuum cleaner.



**PAY ATTENTION THAT AFTER CLEANING ALL DISMOUNTED PARTS ARE REINSTALLED HERMETICALLY.**

## SUMMER STOP

After cleaning the hearth, chimney and hood, totally eliminating the ash and other eventual residues, close all the doors of the hearth and the relevant registers; in case you disconnect the appliance from the chimney you must close its openings in order to let work others possible appliances connected to the same flue.

WE SUGGEST PERFORMING THE CLEANING OPERATION OF THE FLUE AT LEAST ONCE PER YEAR; VERIFYING IN THE MEANTIME THE ACTUAL STATUS OF THE ROPE SEALS, WHICH CANNOT ENSURE THE GOOD OPERATION OF THE EQUIPMENT IF THEY ARE NOT IN GOOD CONDITION AND ARE NOT MAKING A GOOD SEAL! IN THIS CASE THE SEALS MUST BE REPLACED.

IN PRESENCE OF DAMPNES IN THE ROOM WHERE THE PRODUCT HAS BEEN PLACED, WE ADVISE YOU TO PUT ABSORBENT SALTS INTO THE HEARTH.



IF YOU WANT TO KEEP FOR LONG THE AESTHETIC LOOK OF THE COOKER IT IS IMPORTANT TO PROTECT ITS INTERNAL WALLS IN ROW CAST IRON WITH NEUTRAL VASELINE.



## TROUBLESHOOTING

PROBLEM	POSSIBLE CAUSES	POSSIBLE SOLUTIONS
<b>The frame of the cooker or its parts change colour</b>	❖ Flue draught pressure too high	❖ CLEAN THE SURFACES; ❖ CONTACT A CHIMNEY SWEEP TO INSTALL AN AUTOMATIC DRAFT REGULATOR. IF THIS IS NOT POSSIBLE, INSTALL A BUTTERFLY VALVE IN LINE WITH CURRENT LEGISLATION IN FORCE.;
<b>Bended oven and chipped enamel</b>	❖ FLUEDRAUGHTPRESSURETOOHIGH	❖ SMALLENAMELCHIPSDONOTCOMPROMISETHECORRECTFUNCTIONINGOF THE APPLIANCE.INCASEOFMAJORDAMAGESCONTACTTHECUSTOMERSERVICE. ❖ CONTACT A CHIMNEY SWEEP TO INSTALL AN AUTOMATIC DRAFT REGULATOR. IF THIS IS NOT POSSIBLE, INSTALL A BUTTERFLY VALVE IN LINE WITH CURRENT LEGISLATION IN FORCE.
<b>Rust on the stainless steel cooking plate</b>	❖ A SLIGHT COAT OF RUST ON THE WHOLE SURFACE OF THE COOKING PLATE MAY DEPEND ON WET AIR (COOKING STEAM)	❖ GRIND THE SURFACE; ❖ ONLY WHEN THE PLATE IS COLD, GREASE THE SURFACE WITH NON ACID GREASE (VASELINE OR PARAFFIN OIL); ❖ ONLY WHEN THE PLATE IS LUKEWARM, CLEAN WITH A SOFT CLOTH

## DISPOSAL

### INFORMATION FOR MANAGEMENT OF ELECTRIC AND ELECTRONIC APPLIANCE WASTE CONTAINING BATTERIES OR ACCUMULATORS



This symbol, which is used on the product, batteries, accumulators or on the packaging or documents, means that at the end of its useful life, this product, the batteries and the accumulators included must not be collected, recycled or disposed of together with domestic waste. Improper management of electric or electronic waste or batteries or accumulators can lead to the leakage of hazardous substances contained in the product. For the purpose of preventing damage to health or the environment, users are kindly asked to separate this equipment and/or batteries or accumulators included from other types of waste and to arrange for disposal by the municipal waste service. It is possible to ask your local dealer to collect the waste electric or electronic appliance under the conditions and following the methods provided by national laws transposing the Directive 2012/19/EU.

Separate waste collection and recycling of unused electric and electronic equipment, batteries and accumulators helps to save natural resources and to guarantee that this waste is processed in a manner that is safe for health and the environment.

For more information about how to collect electric and electronic equipment and appliances, batteries and accumulators, please contact your local Council or Public Authority competent to issue the relevant permits.